

Waterproof Checkweighing Scales

# PS-SJ-WP

Series



*Weighing at the  
Speed of Lights!*

**AND**  
A&D Company, Ltd.

Discover Precision  
<http://www.aandd.jp>

# Reduce Overfilled Packs and Increase Packing Speed

Fresh produce relies heavily on manual packing processes, often utilizing casual labor to pack into punnets/boxes/bags ready for supermarket consumers. On top of the labor cost, the cost of extra produce given away in overfilled packs can add up to thousands of dollars per week if unchecked.

The SJ-WP series offers a simple solution, utilizing programmable high speed traffic (or comparator\*<sup>1</sup>) lights rather than focusing on a numeric weight display.

\*<sup>1</sup> Function to indicate whether the measured weight is within the designated limits

## Bright and Multi-Colored 5-Step LED Comparator Lights

People respond to these signals faster than just looking at numbers. Green means 'Go', red means 'Stop' (and yellow means 'Warning' in the case of five-level comparison).

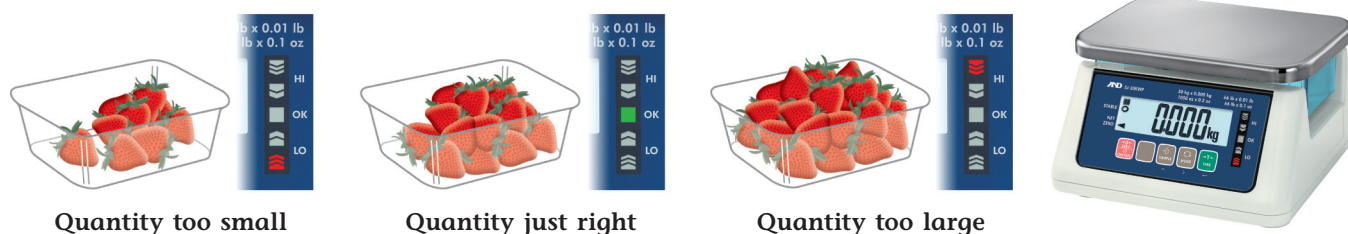

Comparisons can be made in three\*<sup>2</sup>, five, or even seven levels for grading purposes. The scale can **save up to 10 sets of limit values** for fast and simple changeover to different pack sizes/formats.

\*<sup>2</sup> Default setting



Why is the load cell (weight sensor) mounted outside rather than inside the housing?

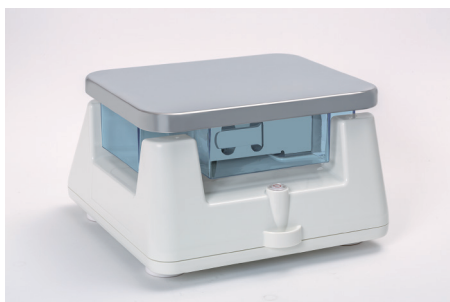

This innovative design allows the device to be completely sealed from moisture without compromising the weighing speed and stability due to up and down movement of the load cell changing the air pressure inside. As a result, the SJ-WP series can **stabilize in 0.5 seconds or less**\*<sup>3</sup>, which further helps to improve factory productivity and efficiency.

\*<sup>3</sup> Subject to the weighing environment, display resolution and response characteristic setting

## IP67 Dust and Waterproof\*4 Construction

In addition to packaging fruits and vegetables, the SJ-WP series is also ideal for weighing wet objects (e.g. fish) or fine powders that easily scatter (e.g. flour). After use, residues can be rinsed with water quickly to keep the scale always clean and hygienic.

For thorough washing, you can strip down the scale by removing (1) the weighing pan with the stainless steel (SUS304) cover and (2) pan support with transparent overhanging shield panels, and then (3) soak the scale directly in water with pH-neutral detergent.

\*4 Permits no infiltration of water while immersed to a depth of 1 meter for 30 minutes

(1)



(2)



(3)



The aluminum load cell of the SJ-WP series is treated with alumite and silicon to be anti-corrosive and withstand long-term use in wet environments.

## Other Useful Features

- ✓ Large LCD digits (26 mm height) with white backlight that provides excellent visibility in dim light
- ✓ Unparalleled, 5000-hour continuous operation with normal batteries\*5
- ✓ Key lock function to prevent operators from making unwanted changes to the scale settings
- ✓ Auto power OFF function to avoid wasting power when the scale is inactive for a set period (5 to 60 minutes) of time
- ✓ Four selectable weighing resolutions: 1/3,000, 1/6,000 (or 1/7,500), 1/12,000 (or 15,000), and 1/30,000
- ✓ Multiple weighing units: gram, kilogram, pound, ounce, troy ounce, pound-ounce, tael (Singapore/HK jewelry/Taiwan), tola, and Newton
- ✓ Counting mode to count a number of small pieces of the same weight instantly and precisely
- ✓ Response characteristics adjustable depending on the degree of vibration and draft at the location
- ✓ Take-away check weighing possible using auto-tare and negative comparison functions

\*5 With 6 D alkaline batteries, LED and backlight off

### Take-Away Check Weighing



Tare the initial weight (either manual or automatic).



Take out the content for the target weight.



The scale performs tare automatically and returns the display to zero.

## Specifications

		PS-SJ-3000WP	PS-SJ-6000WP	PS-SJ-15KWP	PS-SJ-30KWP
kg	Capacity	3	6	15	30
	Minimum display	0.0001	0.0002	0.0005	0.001
		0.0002	0.0005	0.001	0.002
		0.0005*	0.001*	0.002*	0.005*
	0.001	0.002	0.005	0.01	
lb	Capacity	6.6	13	33	66
	Minimum display	0.0002	0.0005	0.001	0.002
		0.0005	0.001	0.002	0.005
		0.001*	0.002*	0.005*	0.01*
	0.002	0.005	0.01	0.02	
oz	Capacity	105	210	520	1050
	Minimum display	0.005	0.01	0.02	0.05
		0.01	0.02	0.05	0.1
		0.02*	0.05*	0.1*	0.2*
	0.05	0.1	0.2	0.5	
lb-oz	Capacity	6	13	33	66
	Minimum display	0.1			
Counting	Number of samples	5, 10, 20, 50 or 100			
	Maximum count	120,000			
Repeatability (standard deviation)		0.5 g	1 g	2 g	5 g
Linearity		±1 g	±2 g	±5 g	±10 g
Sensitivity drift		±50 ppm / °C (5 °C to 35 °C / 41 °F to 95 °F)			
Display	Weight display	7 segment LCD (character height: 26 mm) with white LED backlight			
	Comparator lights	Tricolor 5-step LED: red / yellow / green / yellow / red			
Display update		20 times / second			
Weighing units		g, kg, lb, oz, ozt, lb-oz, tl (tael), t (tola), pcs (counting), N			
Operating temperature		-10 °C to 40 °C / 14 °F to 104 °F			
Battery life (with LED and backlight OFF)		Approx. 5,000 hours with 6 D alkaline batteries Approx. 2,000 hours with 6 D manganese batteries			
Weighing pan size		232 (W) × 192 (D) mm / 9.13 (W) × 7.56 (D) in			
External dimensions		236 (W) × 260 (D) × 148 (H) mm / 9.3 (W) × 10.2 (D) × 5.8 (H) in			
Weight		Approx. 4 kg / 9 lb			
Standard accessories		Instruction manual, screwdriver, cleaning pick (one sheet)			

\* Default setting

## Dimensions (mm/inches)

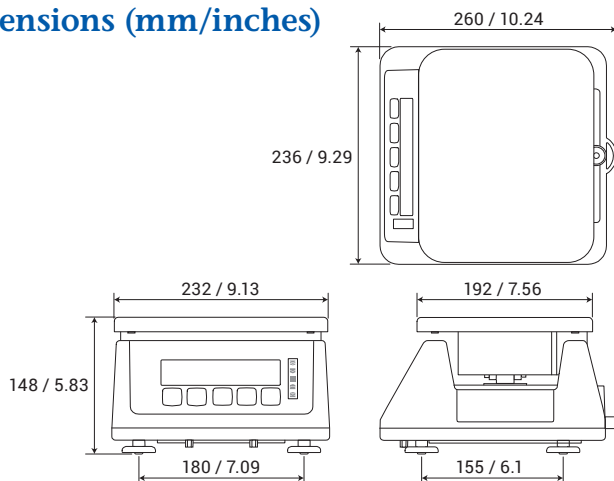

**AND**  
A&D Company, Ltd.

## Discover Precision

West Australian Distributor:

### Perth Scale & Slicer

Unit 1, 195 Bannister Road  
Canning Vale, WA 6155  
Ph: 08 9256 2544 Web:  
[www.perthscale.com.au](http://www.perthscale.com.au)